



ZELIX MEMBRANeKINETICS®

integrates essential colloid chemical functions of natural membranes.

And strengthens the properties of colloids with electrokinetics.

Membrane filtration of process liquids, containing organic and/or inorganic matter has high potentials.

ZELIX MeK boosts the filterability and functionality of colloids.

Following Nature's Design

MEMBRANES have a variety of functions in organic structures. They transport, they separate. They generate and transmit electrical signals. They activate messengers, agents, enzymes ...

These organics are structured in colloidal, microscopic particles. Their electrical charge determines the reactions with other colloids, with the surrounding liquid - and with membranes. The development of artificial membranes was closely linked to colloid-chemical research.

However, the industrial break-through of membrane filtration followed by the crossflow technology, which is not multifunctional, but focused on the effects of shear forces and pressure. The limited resistance of colloids to shear forces, to pressure, temperature, oxidation etc. can create problems, particularly when used for filtering organic and other sensitive matter (food/ beverages, biotech/chemistry/pharma, pulp/paper, biogas ...).

Nature's Design Applied

PANTREON has consistently developed ZELIX technology for dynamic effect, but for reduced mechanical stress and energy consumption, too.

This has improved the performance compared with other membrane systems. But what about the multifunctional properties of natural membranes?

The patented flow technology of ZELIX creates even more potentials; especially for integrating and implementing essential colloid chemical functions of natural membranes, like kinetic activation.

- to strengthen membrane performance by activating molecular interfaces
- to sustain and strengthen natural functionalities.

**ZELIX MEMBRANE.KINETICS -
Nature's Design Applied -
by Activated Interfaces and
Natural Functionalities**

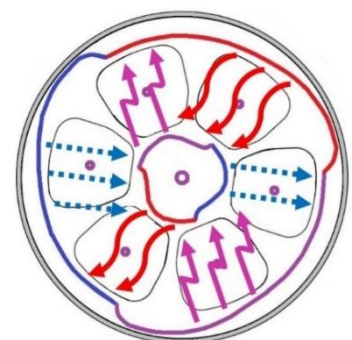

The way

Due to their special properties most inorganic or organic colloids, like proteins, are well filterable and fractionable. Their stability is adapted to their evolutionary milieu, which limits industrial processing. Temperature, pressures, shear forces, air/oxidation can lead to denaturation and changed functionalities. Changes to increased gel formation, to stabilize foam and emulsions etc. may be useful for industrial processes downstream; but not for the ability to filter and fractionate with membranes.

Beyond that, e.g., when proteins' oxidation can lead to compromised bioavailability and loss of nutritive value.

The ZELIX system has been developed to **efficient, smart dynamics**, especially for viscous liquids, high concentrations, biologically / chemically sensitive ingredients. Thus, the natural colloidal properties of organic and inorganic molecules are used positively, e.g.:

Filtration up to 60% protein concentration

According to the *Einstein-Relation*, the mobility/permeation properties of colloids depend primarily on electrical charge and electrical mobility (as well as on particle size and viscosity).

Strengthening these properties by integrated electro kinetics creates a **new standard in membrane technics**.

ZELIX MEMBRANE.KINETICS

ELECTRO KINETICS

> 100% performance increase through activated interfaces

ZELIX flow technology as electrodes set up high-voltage spaces
+ rotating filter modules as counter electrodes
+ mechanical activation through membrane pores.

Cooperation with INNOVUM GmbH
Experience from more than 4.500 electro kinetic projects worldwide.



ZELIX MEMBRANE.KINETICS

DIA-INFUSION

> 100% increased performance by precisely dosed additives

- Infusion of water and additives via the ZELIX flow technology
- Dosing precisely and effectively DIRECTLY into the membrane-activated interfaces.

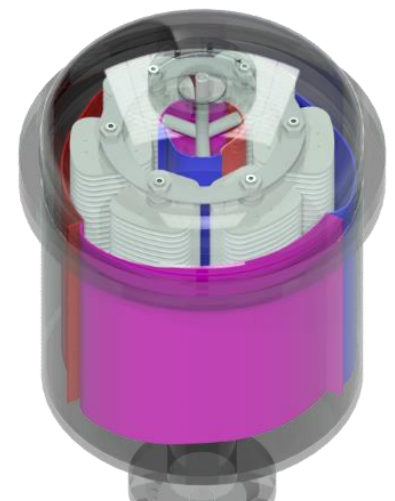

ZELIX 60-10 with multifunctional flow technology

ZELIX MEMBRANE.KINETICS

Δ - TEMP

System dynamics intensify heat-/cooling exchange

- Use of ZELIX flow technology for large area heat-/cooling-exchange zones. and optimized ΔT .

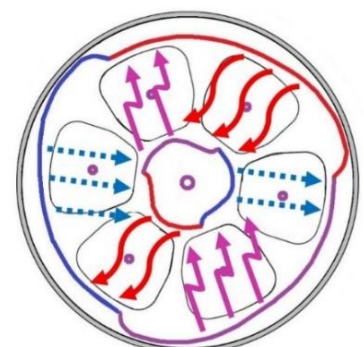

Applications

Due to their colloidal nature, inorganic and organic molecules, eg. proteins, are well membrane-filterable + fractionable.

As example, whey proteins have become highly important in formulated foods. This needs fractionated proteins that are most natural as. But denatured functions are required in food (+ chemical) processing as well, like gelling water binding, stabilizing foams, and emulsions. *)

ZELIX suits for both requirements:

Pre-filtered: Crossflow spiralwound or hollow-fiber modules were a major development and are widely used in food and chemical industries. Eg. denaturation of colloidal proteins is often caused by air intrusion, by oxidation. Thus, the surface charge is reduced, protein mobility, too. The interface activity is stabilized, with negative impact on filtration, fractionation, and concentration of emulsions. However, ZELIX flow features, used as electrodes for high-voltage fields provide unique activation of interfaces. Electric charge strengthens the molecules' hydrophobic, colloidal properties; thus, filtration properties are strengthened, too.

Unfiltered: The ZELIX design enables filtration WITHOUT air intrusion in the retentate and oxidative colloidal damage. Ingredients retain filterability, natural functionality and precise fractionability. Therefore, high nutritional standards for proteins in formulated foods are met.

Such positive impacts enable efficient filtration with broad applications, like food/beverage, biotech/chemistry/ pharma, pulp/paper, biogas ...

Facts

The ZELIX functional and design features offer a wide range of options for consistently developing the system for new applications and for efficient, dynamic membrane performance with low stress on substances. ZELIX, too, requires crossflow for membrane performance. However, strictly following the Reynolds principles, the speeds are reduced and the current is focused via innovative flow geometry.

The filtration is designed to be efficient and gentle on the ingredients..

ZELIX has already an outstanding potential due to its innovative filter technology, its flow technology, rotation technology and the HELIX4D concept. But it still opens up even more innovative potential compared to other processes.

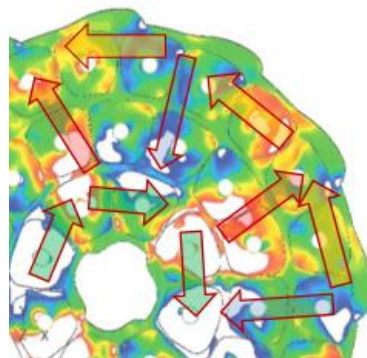

CFD calculations as basis for the smart dynamics of ZELIX flow technology.



Colloids facilitate increased filterability and precise separation due to their charge potentials and by electro-kinetic activation of interfaces. The *Einstein-Relation* defines

decisive parameters for the mobility / diffusion of charged particles. These are electrical charge of particles and their electrical mobility; moreover viscosity of

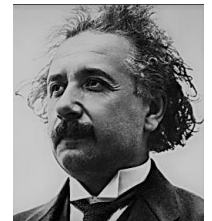

$$D = \frac{\mu_q k_B T}{q}$$

liquids and particles' radii.

It is clear that e.g. milk proteins get their negative surface charge and hydrophobicity broken through oxidation, i.e. by positively charged bi-radical oxygen molecules. The protein's charge, thus mobility and permeation rate decrease. The stabilized interfaces also limit spiralwound's performance in concentrating and fractionating proteins.

Electrokinetics are able to repair such denaturations, can re-activate interfaces.

ZELIX filter technology (left) and flow design (right) as innovative results.



*)Handbook of Food Proteins, p. 30-55

The **spiral wound technique** dominates especially milk processing by membranes. But scientific literature reports fouling, notably with whey proteins, increasing operational cost and efforts.

The *Encyclopedia of Food Science and Nutrition* (p. 3844) reports **air entrainment into the retentate flow** and subsequent changes in whey proteins' **interfacial activity**.

Generally, oxidation and denaturation of



colloids can be expected when **air** is introduced into protein liquids. The surface charge is reduced, the protein mobility, filterability, fractionability and the functionality is impaired.



In contrast to pre-concentrated whey, untreated whey contains hardly any air bubbles. ZELIX keeps good filterability up to >60% protein concentration.



The ZELIX' retentate flow serves just to balance between filter and concentration tanks. This needs much less circulating volume than the spiral wound crossflow. The ZELIX dynamic effect is achieved by rotating filter modules within the filter vessel. This prevents air intrusion as the retentate runs through just **one** loop. But spiral wound requires steady turbulent retentate flow; and has additionally to adjust feed and concentration functions. This is exacerbated by up to **nine** retentate loops, with it increased air intrusion.

The **ZELIX DESIGN PREVENTS retentate air intrusion and oxidative damage** to colloids. Ingredients maintain natural filterability, functionality and can be precisely fractionated. **ZELIX utilizes the properties of proteins and other inorganic or organic colloids.**

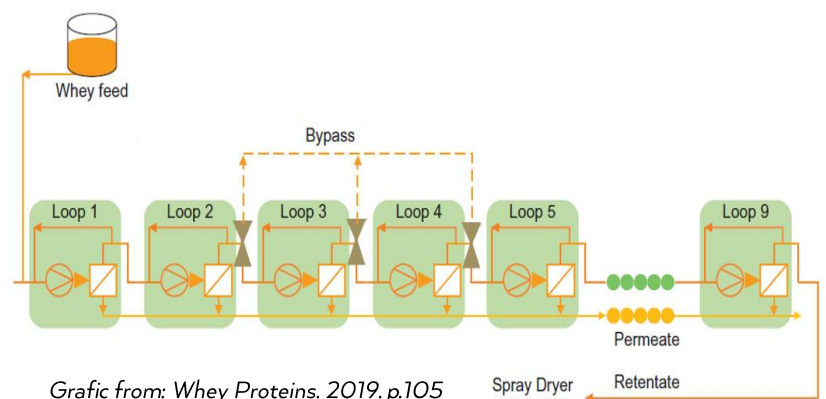
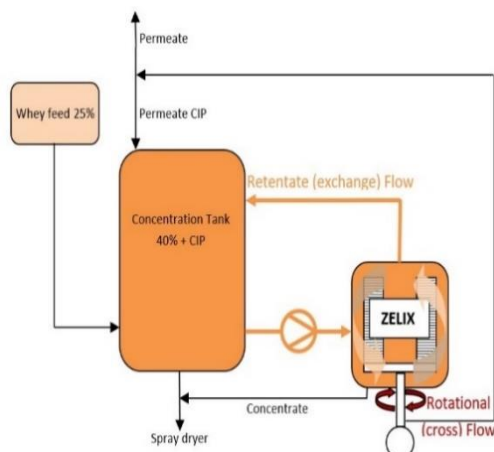

The patented ZELIX design enables integration of process combinations inside its filter vessel next to membrane-active interfaces. This offers even more performance-potentials.

INNOVUM GmbH develops and manufactures patented high-tech electrokinetics. Over 4,500 projects worldwide are proof of the company's broad industrial experience.

Electrokinetics has for long been used upstream of membranes for improving the filterability of liquids. But viscosity can limit the effects. In food processing, the influence of electric fields on hydrophobic and colloidal protein properties has been proven. But there, viscosity limits the effects and the prospects of conventional electrostatic processes as well. (Milk Proteins, 2020, p. 307, 726).

Test experience and research into the colloid-chemical mechanisms of electrokinetics and membrane filtration has led to an industrial sized ZELIX plant with integrated INNOVUM electrokinetic standard modules.

Biogas plants in the food industry can show similar oxidative reactions. E.g. when flotation froth, containing proteins and air are fed in a digester, following molecular surfaces being oxidated and interfaces stabilized; resulting furthermore in reduced microbiological activity, less gas production and -transport ...

Electrokinetics in combination with ZELIX membrane filtration increases the interfacial activity by more than 100% compared to the average before. The effect of the process combination is obvious immediately after the plant's startup and is clear evidence of the ZELIX - INNOVUM process integration. (Grafic below)

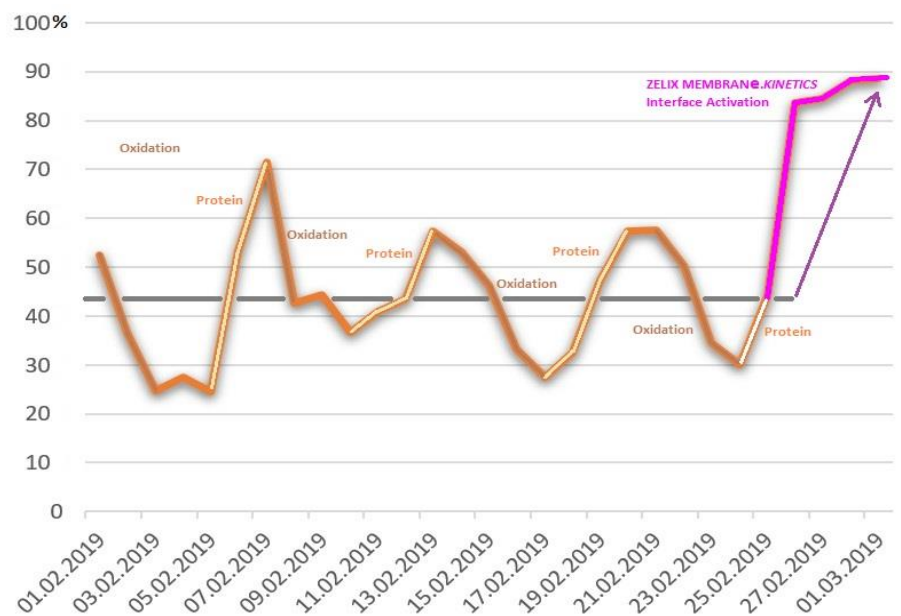
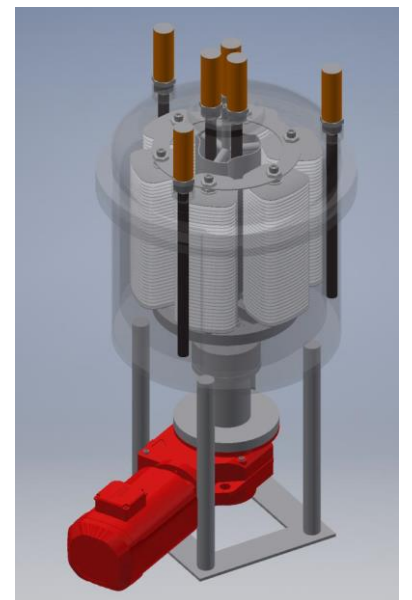

Most industrial process liquids contain colloidal matter like proteins, fats, saccharides etc... But as initial colloid chemical research started on inorganic colloids

ZELIX MEMBRANE.KINETICS®

works in broad applications, such as

Filtration of biomass

- Optimizing biogas processes
- Separation of ammonia nitrogen
- Concentrate digestion residues
- MBR applications
- Ethanol/biodiesel
- Biochemical processes

Chemical / Petrochemical apps

- Alkoxide filtration, acetic acid
- several others

Food / beverages

- Milk, whey, brine
- Wine, fruit juice, beer
- Sugar syrup

Metal / Automobile

- Aluminum
- Degreasing / rinsing water

Water / wastewater treatment

- UF/NF brackish/sea water
- Industrial/municipal wastewater

Pulp and Paper

- Ground wood
- Drainage + power water
- Coating color
- Lye in viscose process

Filtration of oils

- Oils in food or metal industry
- Transformer oils
- Petrochemical processes



ZELIX MEMBRANE.KINETICS

ELECTRO KINETICS

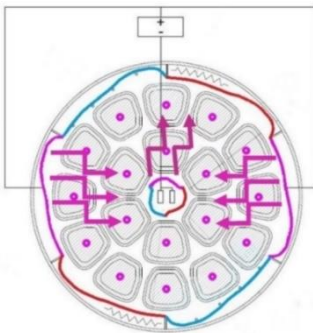

The ZELIX flow technology, used as electrodes for high-voltage fields with rotating filter modules as counter electrodes, create a unique activation of interfaces - above all unique and innovative together with the separative effects of membrane pores directly at the phase boundaries. With the influence of electrical charge on the hydrophobic and colloidal properties, ZELIX shows positive effects even AFTER processes, denaturing molecules (e.g., through oxidation).

ZELIX MEMBRANE.KINETICS

DIA-INFUSION

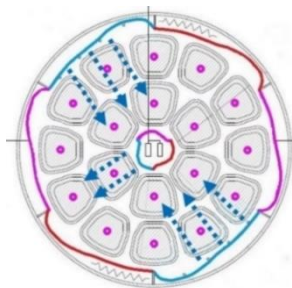

The ZELIX flow technology enables the infusion of auxiliary substances (enzymes, ...) in process media - precisely and most effectively dosed into the interfaces, activated by filter modules and membranes. Auxiliaries are used in a targeted and efficient manner, e.g., to optimize biological/chemical processes.

ZELIX MEMBRANE.KINETICS

Δ - TEMP

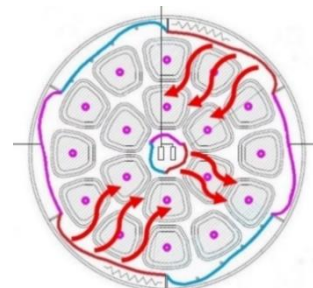

ZELIX flow technology allows large-area heat/cooling exchange zones being integrated. This provides high efficiency thanks to the dynamic and steady flow of process media over the exchange surfaces for optimized ΔT.

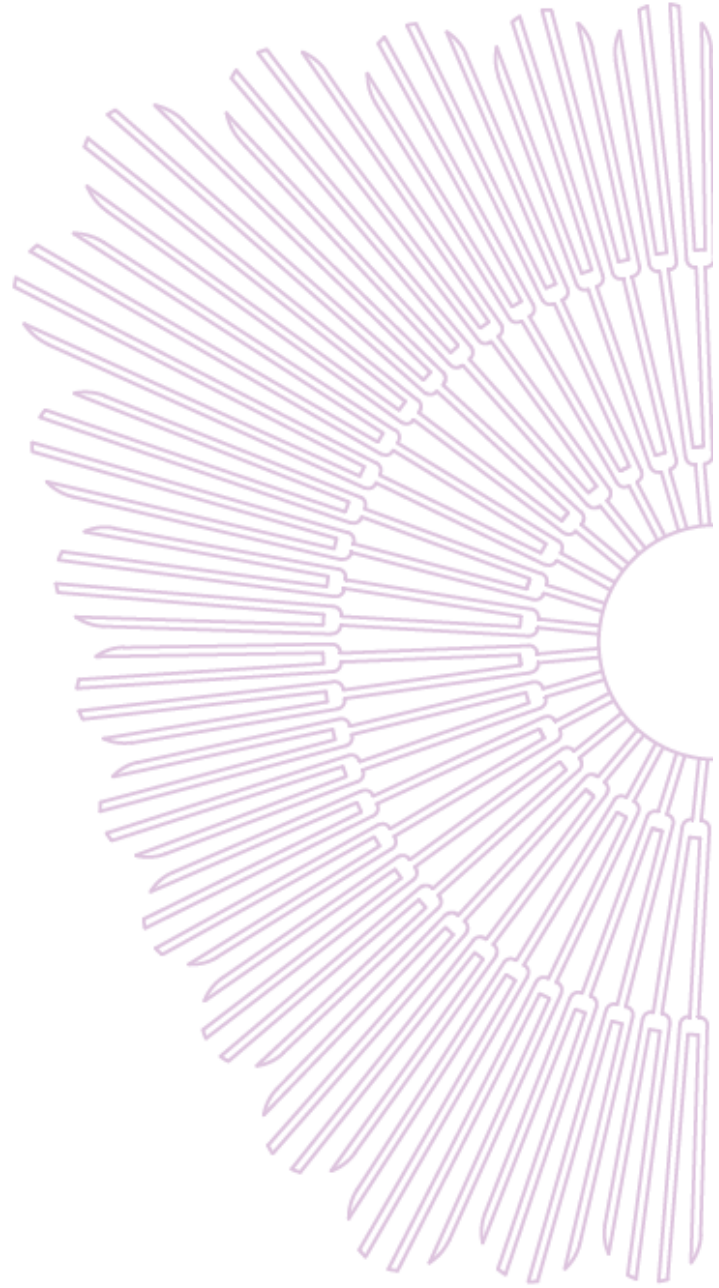

*Applied model of nature also in the design
of the ZELIX filter modules:
The most stable structure of diatoms*



Pantreon GmbH

Krottenseestrasse 47
A-4810 Gmunden
Austria
T +43 (0)7612 20820
F +43 (0)7612 20820 40
office@pantreon.com
www.pantreon.com



Innovum GmbH

Förstergasse 17a
A-6973 Höchst
Austria
T +43 (0)5578 74538
F +43 (0)5578 74538 16
info@innovum.at
www.innovum.at